

1. PACKING LIST

Please check the contents of the HAKKO 937 package and confirm that all the items listed below are included.

- HAKKO 937 Station 1
- Card 1
- Soldering Iron (HAKKO 900 (S), 907 or 908) 1
- HAKKO Iron Holder (With Cleaning Sponge) 1
- Coupling Band 1
- Instruction Manual 1

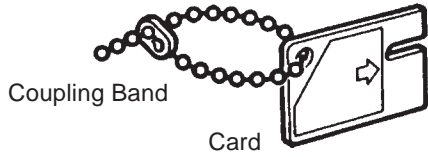
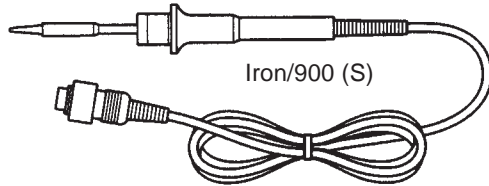
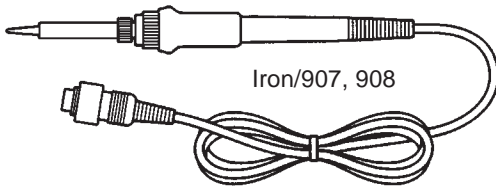
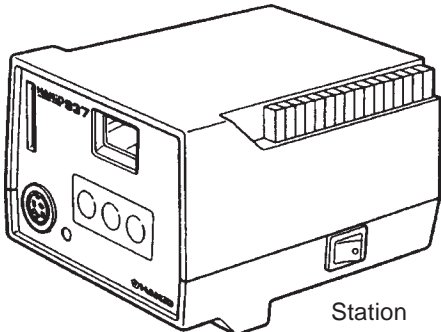
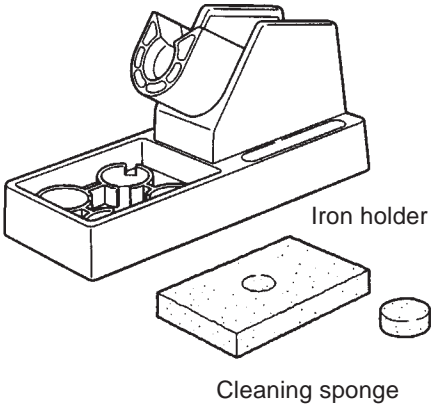

2. SPECIFICATIONS

Name	HAKKO 937
Power Consumption	60W

●Station

Part Name	937 Station ESD
Output Voltage	24V AC
Temperature Range	200~480°C/400~899°F
Dimensions	120 (W) × 93 (H) × 140 (D)mm (4.7 × 3.7 × 5.5 in.)
Weight (W/O Cord)	1,300 g (2.9 lbs.)

- The tip temperature was measured using HAKKO 191 thermometer.
- Specifications and design are subject to change without notice.

●Soldering Iron

	900S-ESD	907-ESD	908-ESD
Power Consumption	24V AC-50W		
Tip to Ground Resistance	Under 2 Ω		
Tip to Ground Potential	Under 2 mV		
Heating Element	Ceramic heater		
Cord Assembly	1.2 m (4 ft.)		
Total Length (w/o Cord)	176 mm (7 in.)	190 mm (7.5 in.)	200 mm (7.9 in.)
Weight (w/o Cord)	25 g (0.06 lbs.)	44 g (0.09 lbs.)	54 g (0.12 lbs.)

3. WARNINGS AND CAUTIONS

In this instruction manual, “WARNING” and “CAUTIONS” are defined as follows.

WARNING

 **WARNING:** Misuse may potentially cause death of, or serious injury to, the user.

 **CAUTION :** Misuse may potentially cause injury to the user or physical damage to the objects involved.

For your own safety, be sure to comply with these precautions.

CAUTION

When the power is on, the tip temperature is between 200°C/400°F and 480°C/ 899°F.

Since mishandling may lead to burns or fire, be sure to comply with the following precautions.

- Do not touch the metallic parts near the Tip.
- Do not use the product near flammable items.
- Advise other people in the work area that the unit can reach a very high temperature and should be considered potentially dangerous.
- Turn the power off while taking breaks and when finished using the unit.
- Before replacing parts or storing the unit, turn the power off and allow the unit to cool to room temperature.

To prevent damage to the unit and ensure a safe working environment, be sure to comply with the following precautions.

- Do not use the unit for applications other than soldering.
- Do not rap the soldering iron against the work bench to shake off residual solder, or otherwise subject the iron to severe shocks.
- Do not modify the unit.
- Use only genuine HAKKO replacement parts.
- Do not wet the unit or use the unit when your hands are wet.
- Do not bend or damage the card. Should the card become bent, do not force the card into the station.
- The soldering process will produce smoke, so make sure the area is well ventilated.
- While using the unit, don't do anything which may cause bodily harm or physical damage.

4. PART NAMES

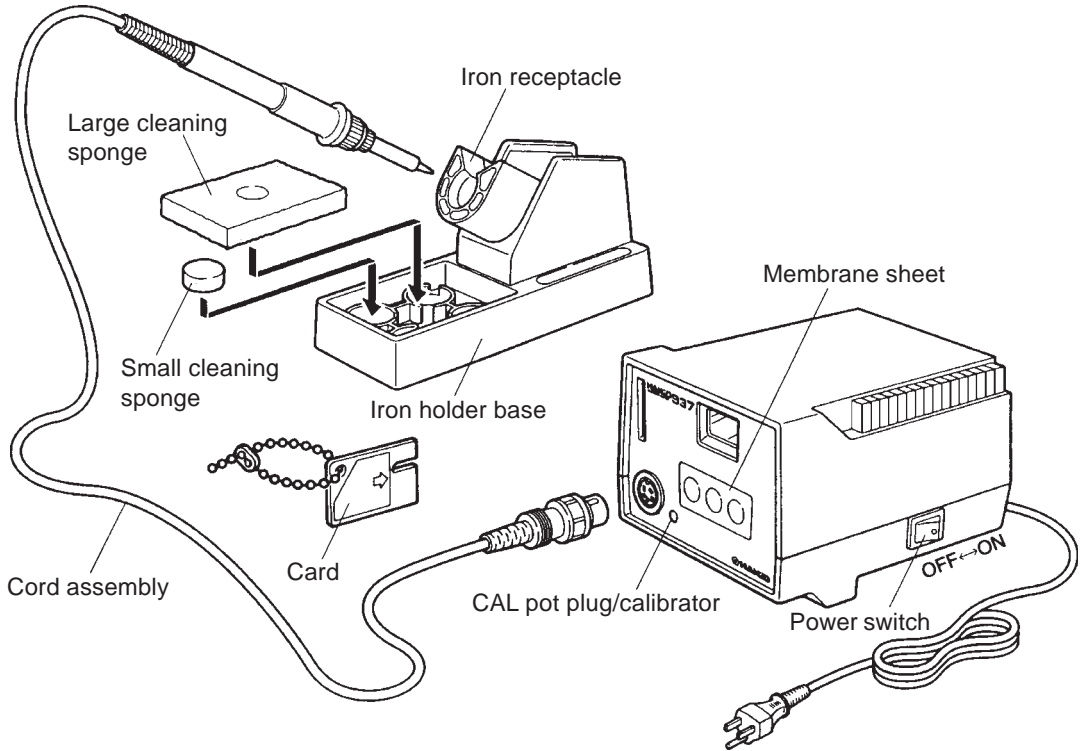

5. SETTING UP & OPERATING THE HAKKO 937

CAUTION : The sponge is compressed. It will swell when moistened with water. Before using the unit, dampen the sponge with the water and squeeze it dry. Failure to do so may result in damage to the soldering tip.

A. Iron holder

1. Small cleaning sponge
Dampen the small cleaning sponge with water and then squeeze it dry. Place it in one of the 4 openings of the iron holder base.
2. Add water to approximately the level as shown. The small sponge will absorb water to keep the larger sponge above it wet at all times.
*The large sponge may be used alone (w/o small sponge & water).
3. Dampen the large cleaning sponge and place it on the iron holder base.

Note: The iron receptacles for the 900 (S) and the 907/908 soldering irons are different. Be sure to use the proper one for each type of soldering iron. (Refer to Parts List).

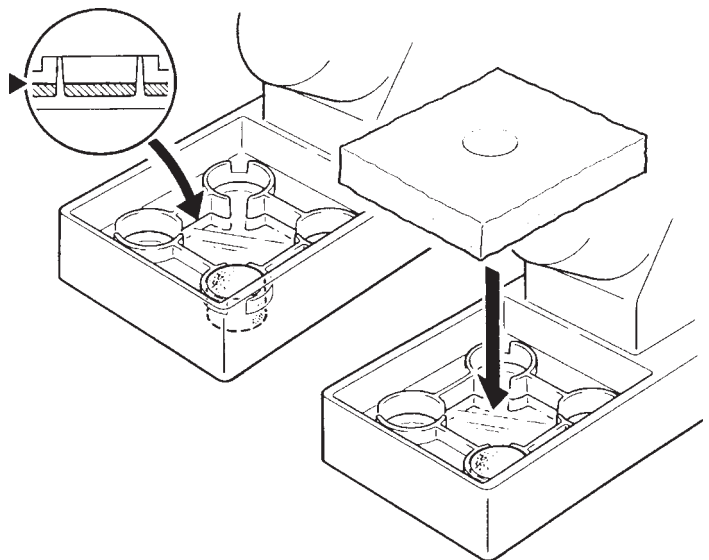

⚠ CAUTION : Be sure to turn off the power switch before connecting or disconnecting the soldering iron. Failure to do so may damage to the Station.

B. Connections

1. Connect the cord assembly to the receptacle.
2. Place the soldering iron in the iron holder.
3. Plug the power cord into the power supply. Be sure to ground the unit.
4. Turn the power switch to ON.

NOTE:

The temperature is preset at 400°C at the factory. (The No.937-4, -5, and -6, are preset at 750°F.) The heater lamp will flicker when the temperature has stabilized.

5. Press  to display the preset temperature. It will be displayed for two seconds.

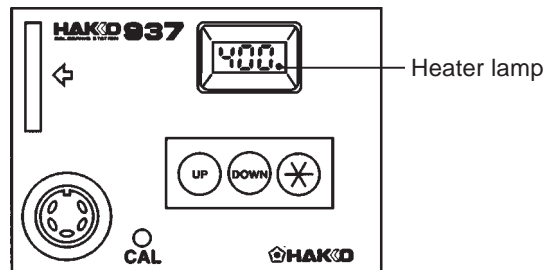
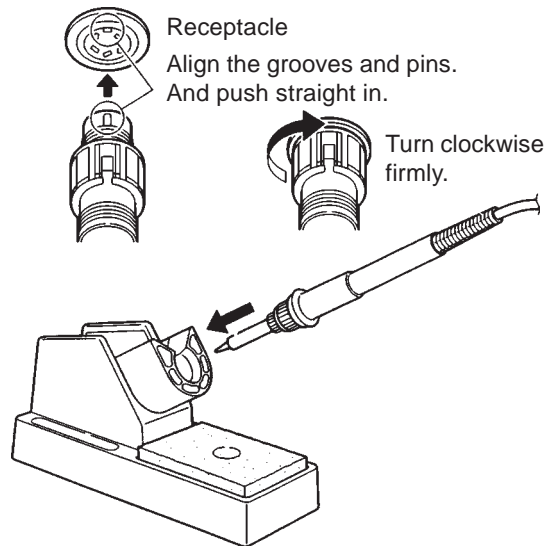

⚠ CAUTION

The soldering iron must be placed in the iron holder when not in use.



C. Set the temperature

Example: Change the temperature from 400°C to 350°C.

1. Insert the card into the card slot on the front panel of the station. The left-most digit in the display (the 100's digit) will begin flashing, indicating that the station is in the temperature setting mode and that the 100's digit can be adjusted.
2. Using the  or  button to increase or decrease the value, select the desired value for the 100's digit. The 100's digit can be set to 2, 3, or 4. Press  when the desired value is displayed. This will cause the middle digit (the 10's digit) in the display to begin flashing.

⚠ CAUTION

Be sure to insert the correct end of the card into the card slot. While setting the temperature, the heating element is off.

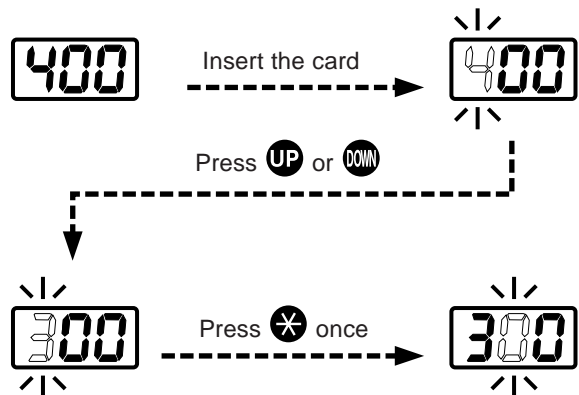

5. SETTING UP & OPERATING THE HAKKO 937

- Again using the **UP** or **DOWN** button, select the desired value for the 10's digit. The 10's digit can be set to **1, 2, 3, 4, 5, 6, 7, 8, 9, or 0**. Press **✳** when the desired value is displayed. This will cause the digit on the right (the 1's digit) in the display to begin flashing.
- Again using the **UP** or **DOWN** button, select the desired value for the 1's digit. The 1's digit can be set to **1, 2, 3, 4, 5, 6, 7, 8, 9, or 0**. Press **✳** when the desired value is displayed. This will store the temperature setting in memory, display the temperature setting, and initiate heater control.

C. Setting or changing the temperature (continued)

To change the temperature setting when the card has been left in the station...

The card

Stacking stations

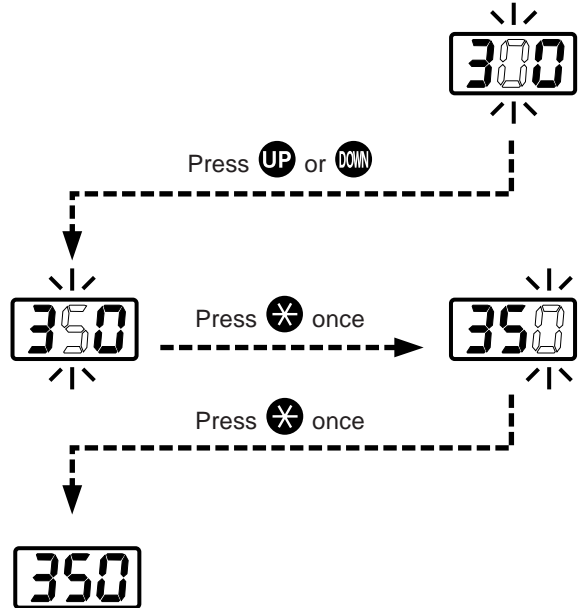

NOTE:

If the power switch is turned off during any step of the temperature adjustment procedure, the setting will not be stored in memory.

- Press **✳** and hold it down for at least one second. The current temperature setting will be displayed for a moment, then the 100's digit will begin flashing, indicating that the station is now in the temperature setting mode. Proceed with the procedure on page 4&5.
 - If **✳** is pressed for less than one second, the present temperature setting will be displayed for two seconds, then the display will again show the tip temperature.
- After setting the temperature, remove the card. The preset temperature cannot be changed until the card is reinserted, even if the power switch is turned off. Thus, the power can be turned off and on without having to reset the temperature each time, and accurate and safe temperature control is assured.
 - Any HAKKO 937 card can be used with any HAKKO 937 station.
 - The HAKKO 937 will operate normally with a card inserted. If the power is turned off while the card is inserted, when the power is turned on again, the previously set temperature will be used to heat up the soldering iron.
- For greater convenience and soldering efficiency, two stations can be securely stacked.

6. PARAMETERS

Parameter input mode

1. Centigrade or Fahrenheit temperature display

2. Heater-error temperature tolerance

(see **Heater** error on page 11)





Heater-error temperature range

Centigrade: 30 - 150°C

Fahrenheit: 60 - 300°F

3. Room temperature compensation value (test mode)

The HAKKO 937 has three user-adjustable or viewable parameters: a) Temperature display mode (Centigrade or Fahrenheit), b) Heater-error temperature tolerance, and c) Room temperature compensation value (test mode). Once parameter-input mode is entered, these parameters are set in the order shown. Once all three parameters have been set, normal operation is resumed.

1. Turn off the power switch.
2. Press and hold the **UP** and **DOWN** buttons simultaneously, and turn on the power switch.
3. Continue holding down the **UP** and **DOWN** buttons until the display indicates either  (for Centigrade) or  (for Fahrenheit). The station is now in parameter input mode.
4. Press either the **UP** or **DOWN** button to alternately display  and .
5. When the desired method is displayed, press **✱**. The heater-error temperature will now be displayed and the left-most digit (100's digit) in the display will begin flashing.

The heater-error temperature tolerance parameter is entered in the same manner as used to set the temperature. (see pg. 4, 5, steps 2-4.)

Be sure to use a value within the allowable range. (see chart at left). If a value outside this range is selected, the display will again flash the 100's digit. Should this occur, re-enter a correct value.

After setting the heater-error temperature tolerance, the display will show the room temperature compensation value (test mode).

This is the measured temperature of the soldering iron tip. It is used to calibrate the tip temperature. (see pg. 7, Calibration of iron temperature)

No inputs are made here. The display will not blink nor will the heater receive power. Press **✱** to complete parameter input. The soldering temperature setting will be displayed for two seconds, then power will be supplied to the heater and normal temperature control will begin.

7. CALIBRATION OF IRON TEMPERATURE

Calibration is required whenever the soldering iron, or its heating element or tip have been replaced. Although either of the two following calibration methods can be used, calibration with a tip thermometer is more accurate.

Calibration with a tip thermometer

We recommend the HAKKO 191 thermometers and HAKKO 192 soldering tester for measuring the tip temperature.

Calibration with a room thermometer (test mode)

1. Set the temperature to 400°C (750°F).
2. When the temperature stabilizes, remove the CAL pot plug.
3. Using a regular or small cross point screwdriver, turn the screw marked CAL on the front panel of the station until the tip thermometer indicates a temperature of 400°C (750°F).

Note: Turn the screw clockwise to increase the temperature and counterclockwise to reduce the temperature.

4. Reattach the CAL pot plug.

1. Allow the HAKKO 937 to cool to room temperature. (approx. 1 hour)
2. Press and hold down the **UP** and **DOWN** buttons simultaneously, and turn the power switch on. (see **Parameters** on pg. 6)
3. Following the procedure on page 6, display the room temperature compensation value (test mode). This is the measured temperature of the soldering iron tip.

CAUTION

If a mistake is made while performing steps 2 or 3, the station will start up normally and the heating element will begin warming up. Should this happen, turn the station off and wait until it has again cooled to room temperature.

4. Using a regular or small cross point screwdriver, turn the screw marked CAL on the front panel of the station until the display indicates the room temperature plus or minus the value in the calibration chart on page 8.
5. Press ***** to complete the calibration. Power will now be supplied to the heater and normal temperature control will begin.

8. CALIBRATION CHART

Example: To calibrate the 900M-T-LB tip at a room temperature of 22°C (70°F), adjust the CAL potentiometer until the digital display reads **20 (66)**.

Room temperature: 22°C (70°F)

Compensation value: -2°C (-4°F)

Digital display: 20°C (66°F)

900S		907		908	
Tip No.	Compensation value	Tip No.	Compensation value	Tip No.	Compensation value
900S-T-1.2D	0	900M-T-0.8D	0	900L-T-B	0
900S-T-1.6D	0	900M-T-1.2D	+2°C (+4°F)	900L-T-2B	0
900S-T-2C	0	900M-T-1.6D	0	900L-T-2.4D	0
900S-T-1C	0	900M-T-2.4D	0	900L-T-3.2D	0
900S-T-B	0	900M-T-3.2D	0	900L-T-2C	-5°C (-9°F)
900S-T-I	0	900M-T-1.2LD	0	900L-T-2CF*	-5°C (-9°F)
		900M-T-SB	0	900L-T-3C	0
		900M-T-B	0	900L-T-3CF*	0
		900M-T-LB	-2°C (-4°F)	900L-T-4C	0
		900M-0.5C	0	900L-T-4CF*	0
		900M-0.8C	-2°C (-4°F)	900L-T-5C	0
		900M-T-1C	0	900L-T-5CF*	0
		900M-T-1CF*	0	900L-T-I	-5°C (-9°F)
		900M-T-1.5CF*	0	900L-T-K	+5°C (+9°F)
		900M-T-2C	0		
		900M-T-2CF*	0		
		900M-T-3C	0		
		900M-T-3CF*	0		
		900M-T-4C	0		
		900M-T-4CF*	0		
		900M-T-K	+7°C (+12°F)		
		900M-T-R	0		
		900M-T-RT	0		
		900M-T-SI	0		
		900M-T-I	-2°C (-4°F)		
		900M-T-H	-5°C (-9°F)		
		900M-T-1.8H	-2°C (-4°F)		
		900M-T-S4	+4°C (+7°F)		

9. TIP CARE AND USE

Tip temperature

High soldering temperatures can degrade the tip. Use the lowest possible soldering temperature. The excellent thermal recovery characteristics ensure efficient and effective soldering even at low temperatures. Low temperatures also protect the soldered items from thermal damage.

Cleaning

Clean the tip regularly with a cleaning sponge, as oxides and carbides from the solder and flux can from impurities on the tip. These impurities can result in defective joints, of reduce the tip's heat conductivity.

When using the soldering iron continuously, be sure to loosen the tip and remove any oxide at least once a week. This helps prevent seizure and reduction of the tip temperature.

When not in use

Never leave the soldering iron sitting at a high temperature for long periods, as the tip's solder plating will become covered with oxide, which can greatly reduce the tip's heat conductivity.

After use

Wipe the tip clean and coat it with fresh solder. This helps prevent tip oxidation.

10. MAINTENANCE

Inspect and clean the tip

1. Set the temperature to 250°C (482°F)
2. When the temperature stabilizes, clean the tip with the cleaning sponge and check the condition of the tip.
3. If there is black oxide on the solder-plated portion of the tip, apply new flux-contained solder and wipe the tip on the cleaning sponge. Repeat until the oxide is completely removed. Coat with new solder.

⚠ CAUTION

Never file the tip to remove oxide.

4. If the tip is deformed or heavily eroded, replace it with a new one.

11. TIP STYLES

907

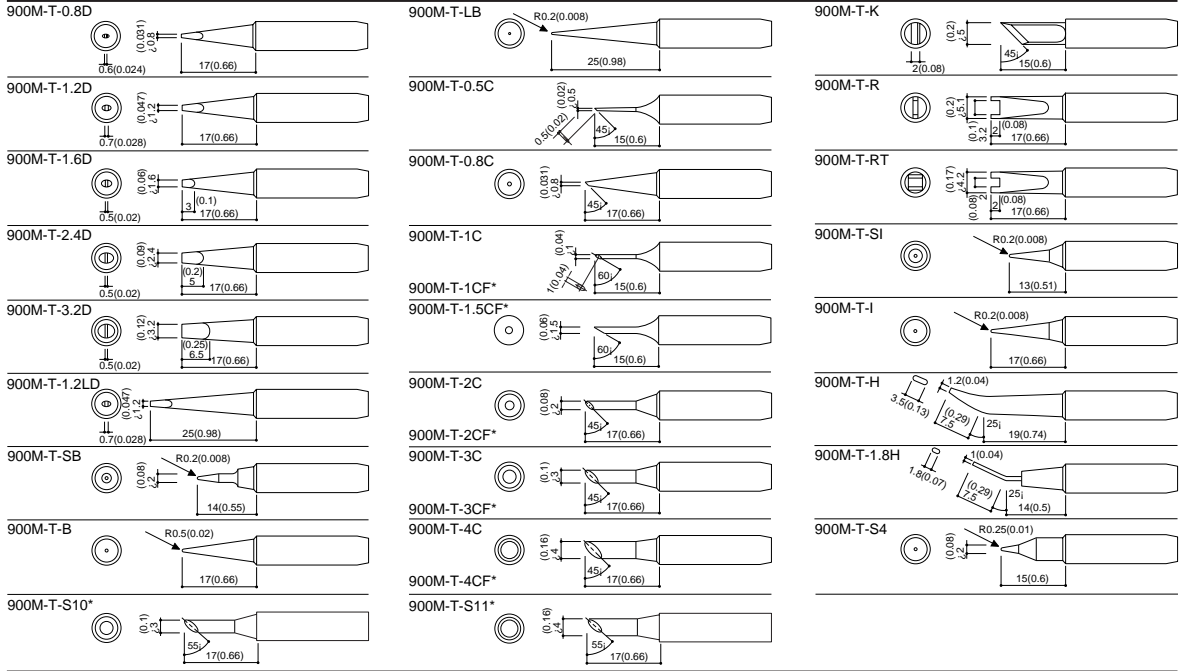

*900M tip Out Diam ϕ 6.5

908 For heavy duty soldering HAKKO recommends the 908 iron with heavier tips.

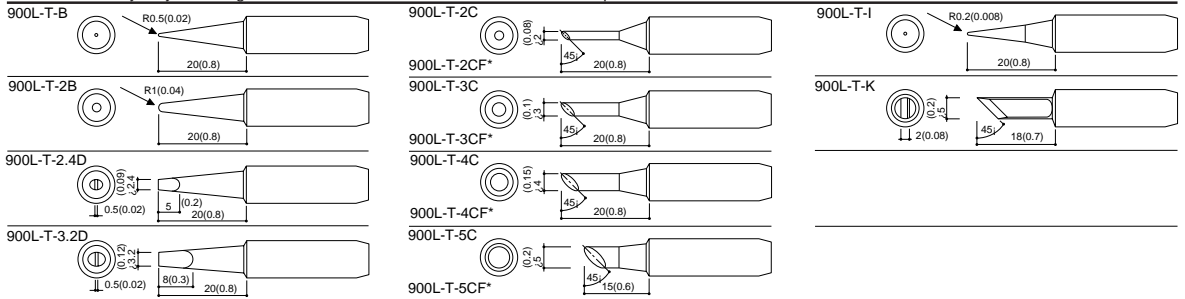

*900L tip Out Diam ϕ 8.5

*These tips are tinned flat only.

900S For micro soldering HAKKO recommends the 900S iron with fine tips.

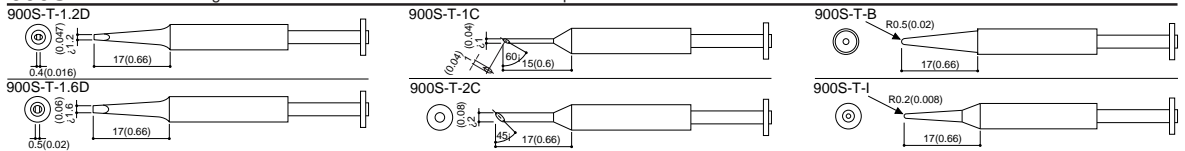

*900S tip Out Diam ϕ 5.8

12. ERROR MESSAGES

The HAKKO 937 displays various error messages whenever there is a problem. If the following messages are displayed, refer to the **Troubleshooting Guide** on page 12.

System error



When the power is turned on, the system automatically checks its memory and the stored programmed. If a problem is found, the unit will display  and all operations will come to a complete stop.

Sensor error



If there is a possibility of a failure of the sensor or any part of the sensor circuit,  will be displayed and power to the soldering iron will be cut off.

Heater error

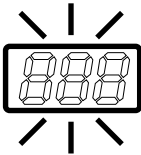

If power is being sent to the soldering iron and the tip temperature goes below the heater-error temperature tolerance setting, the temperature display will begin flashing on and off. This indicates a possible heater malfunction.

For example, assume that the temperature setting is 400°C (750°F) and the heater-error temperature tolerance value is 50°C (100°F). If the temperature of the soldering iron goes below 350°C (650°F), even though the heater is receiving power, the display will begin flashing, indicating a possible heater malfunction.

Example: $400 - 50 = 350^{\circ}\text{C}$ ($750 - 100 = 650^{\circ}\text{F}$)
The display begins flashing.

Note: If the temperature begins to rise again, the display will stop flashing, even if the displayed temperature is below 350°C (650°F).

13. TROUBLESHOOTING GUIDE

⚠ WARNING : * Disconnect the power plug before servicing.
Failure to do so may result in electric shock.
* If the power cord is damaged, it must be replaced by the manufacturer, its service agent or similarity qualified person in order to avoid personal injury or damage to the unit.

Problem

The unit does not operate.

Check

- **Is the fuse blown?**
Determine why the fuse blew and eliminate the cause, then replace the fuse.
 - Is the inside of the iron short-circuited?
 - Is the grounding spring touching the heating element?
 - Is the heating element lead twisted and short-circuited?
- **Is the power cord broken?**
Replace it with a new cord.

The tip does not heat up. Sensor error or heater error is displayed.

- **Is the power cord and/or connecting plug disconnected?**
Connect it.
- **Is the soldering iron cord broken?**
See **Check for a broken heating element or cord assembly**, pg. 14.
- **Is the heating element broken?**
See **Check for a broken heating element or cord assembly**, pg. 14.

The tip heats up intermittently.

- **Is the soldering iron cord broken?**
See **Check for a broken heating element or cord assembly**, pg. 14.

Solder will not wet the tip.

- **Is the tip temperature too high?**
Set an appropriate temperature.
- **Is the tip coated with oxide?**
Clean the tip. (See **Tip care and use**, pg. 9.)

13. TROUBLESHOOTING GUIDE

The tip temperature is too low.

- **Is the tip coated with oxide?**
Clean the tip. (See **Tip care and use**, pg. 9.)

- **Is the iron calibrated correctly?**
Recalibrate. (see **Tip care and use**, pg. 9.)

Contact your nearest HAKKO representative.

Heater errors are frequently displayed

- **Is the tip too small for the items to be soldered?**
Use a heavier tip.
- **Is the heater-error temperature tolerance setting too low?**
Increase the value of the setting.

14. CHECKING FOR BREAKAGE OF THE HEATING ELEMENT AND CORD ASSEMBLY

Disconnect the plug and measure the resistance value between the connecting plug pins as follows.

If the values of 'a' and 'b' are outside the above value, replace the heating element (sensor) and/or cord assembly. Refer to Procedures 1 and 2.

If the value of 'c' is over the above value, remove the oxidization film by lightly rubbing with sand-paper or steel wool the points shown below.

1. Broken Heating Element

a	Between pins 4&5 (Heating Element)	2.5 - 3.5 Ω (Normal)
b	Between pins 1&2 (Sensor)	43 - 58 Ω (Normal)
c	Between pin 3&Tip	Under 2 Ω

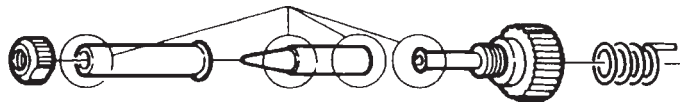
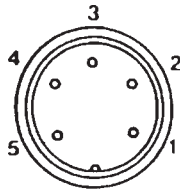

Disassembling the 907/908

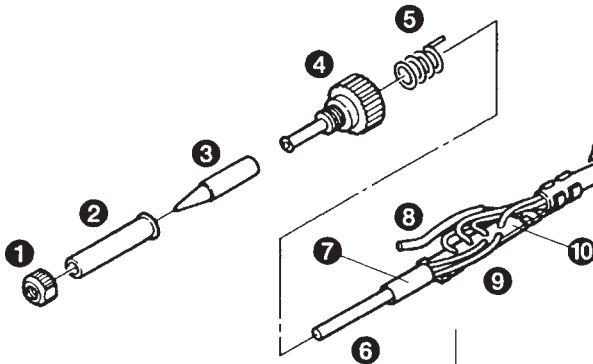

Heating Element (Red) Sensor (Blue)



1. Turn the nut (1) counterclockwise and remove the tip enclosure (2), the tip (3).
2. Turn the nipple (4) counterclockwise and remove it from the iron.
3. Pull both the heating element (6) and the cord assembly (11) out of the handle (12). (Toward the tip of the iron).
4. Pull the grounding spring (5) out of the sleeve.

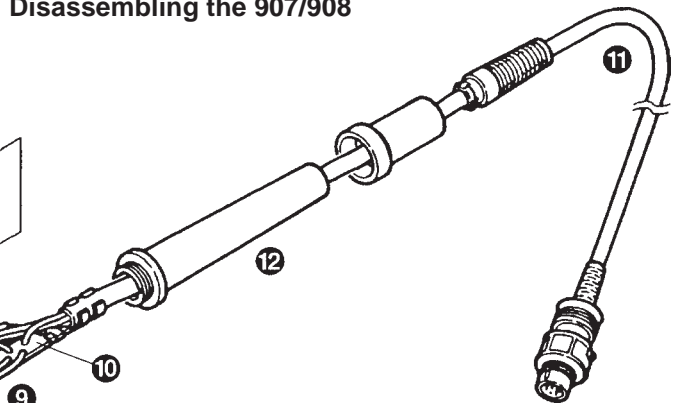

Measure when the heating element is at room temperature.

1. Resistance value of heating element (RED) 2.5 - 3.5 Ω
2. Resistance value of sensor (BLUE) 43- 58 Ω

If the resistance value is not normal, replace the heating element.
(Refer to the instructions included with the replacement part.)

After replacing the eating Element,

1. Measure the resistance value between 1) pins 4 & 1 or 2) pins 5 & 1 or 2. If it is not ∞, the heating element and sensor are touching. This will damage the P.W.B.
2. Measure the resistance value 'a', 'b', and 'c' to confirm that the leads are not twisted and that the grounding spring is properly connected.

14. CHECKING FOR BREAKAGE OF THE HEATING ELEMENT AND CORD ASSEMBLY

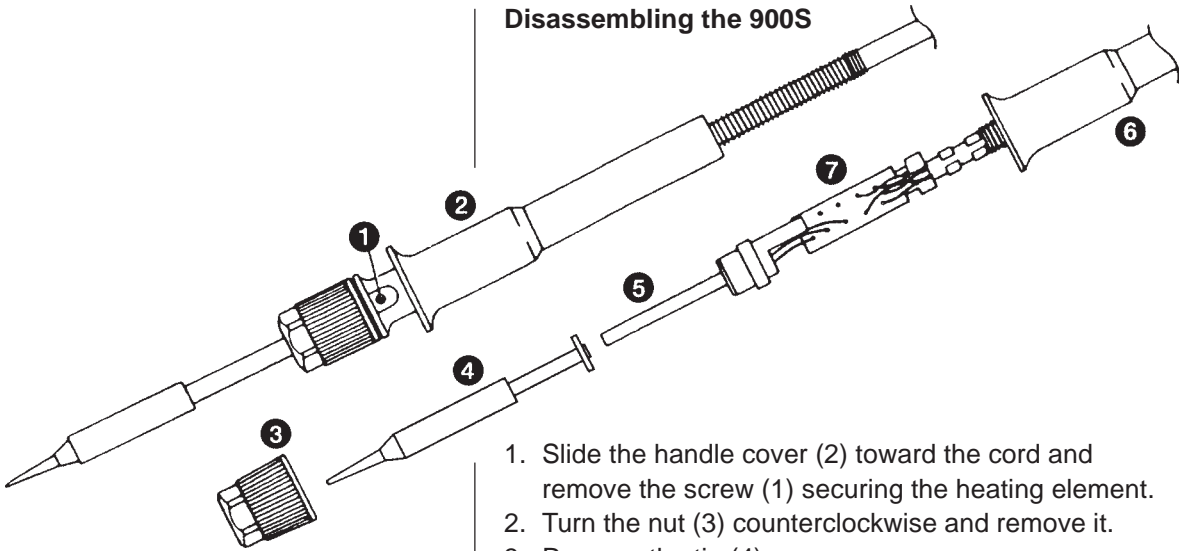

1. Slide the handle cover (2) toward the cord and remove the screw (1) securing the heating element.
2. Turn the nut (3) counterclockwise and remove it.
3. Remove the tip (4).
4. Pull both the heating element (5) and the cord toward the tip of the iron and out of the handle (6).

Measure the resistance values at the sensor and the heating element of the terminal board.

The resistance value should be the same as for the 907, 908.

To replace the heating element, refer to the instructions included with the replacement part.

2. Broken Soldering Iron Cord

There are two methods of testing the soldering iron cord.

⚠ CAUTION

The heater lamp will flicker if the iron temperature is allowed to reach the set temperature. Before replacing the cord, be sure that this is not the reason for the flickering.

1. Turn the unit ON and set the temperature to 480°C (899°F). Then wiggle and kink the iron cord at various locations along its length, including in the strain relief area. If the LED heater lamp flickers, then the cord needs to be replaced.

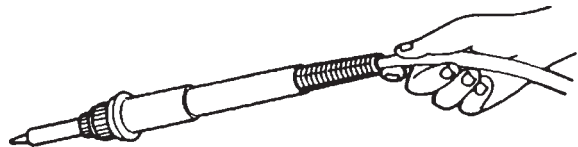

2. Check the resistance between the pin of the plug and the wire on the terminal.
 Pin 1: Red Pin 2: Blue Pin 3: Green Pin 4: White
 Pin 5: Black
 The value should be 0 Ω. If it is greater than 0 Ω or is ∞, the cord should be replaced.

3. Replacing the Fuse

Be sure to use only genuine HAKKO replacement Parts!

Refer to the drawing in the replacement parts section of this manual. Desolder the blown fuse and remove it. Solder on a new one.

15. PARTS LIST

Station

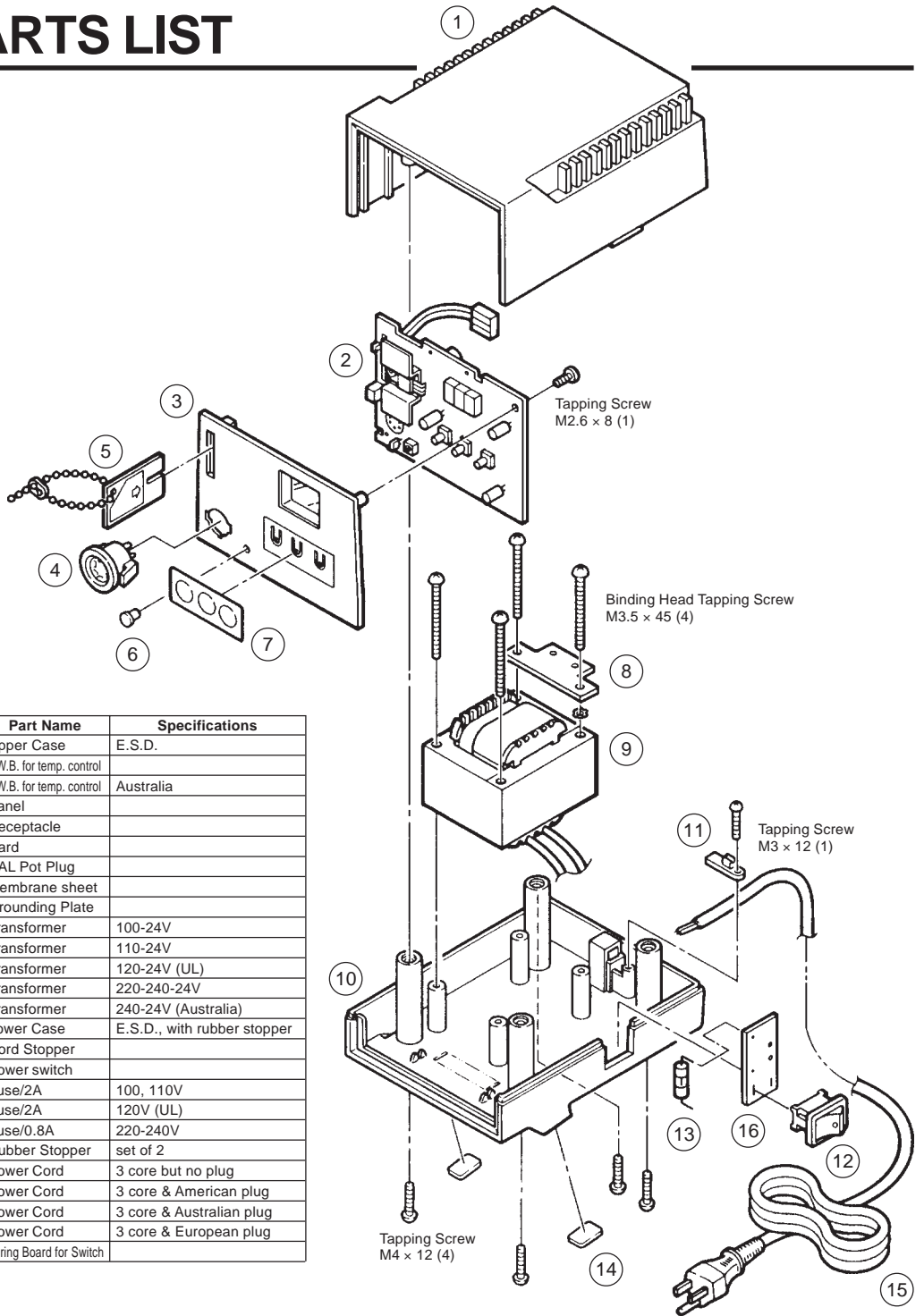

Item No.	Part No.	Part Name	Specifications
①	B2034	Upper Case	E.S.D.
②	B2036	P.W.B. for temp. control	
	B2322	P.W.B. for temp. control	Australia
③	B2035	Panel	
④	B2006	Receptacle	
⑤	B2037	Card	
⑥	B2018	CAL Pot Plug	
⑦	B2047	Membrane sheet	
⑧	B2227	Grounding Plate	
⑨	B2038	Transformer	100-24V
	B2039	Transformer	110-24V
	B2040	Transformer	120-24V (UL)
	B2041	Transformer	220-240-24V
	B2302	Transformer	240-24V (Australia)
⑩	B2002	Lower Case	E.S.D., with rubber stopper
⑪	B2015	Cord Stopper	
⑫	B1084	Power switch	
	B2007	Fuse/2A	100, 110V
⑬	B2224	Fuse/2A	120V (UL)
	B2008	Fuse/0.8A	220-240V
⑭	B2016	Rubber Stopper	set of 2
⑮	B1318	Power Cord	3 core but no plug
	B1319	Power Cord	3 core & American plug
	B2042	Power Cord	3 core & Australian plug
	B2043	Power Cord	3 core & European plug
⑯	B2103	Wiring Board for Switch	

Iron holder

Item No.	Part No.	Part Name	For
①	C1141	Iron Holder	900S
	C1142	Iron Holder	907, 908
②	B2020	Iron Receptacle	900S
	B2021	Iron Receptacle	907, 908
③	B2019	Iron Holder Base	900S, 907, 908
④	A1042	Cleaning Sponge	900S, 907, 908

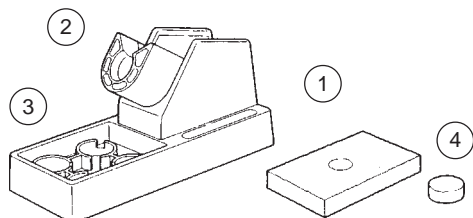

15. PARTS LIST (Iron)

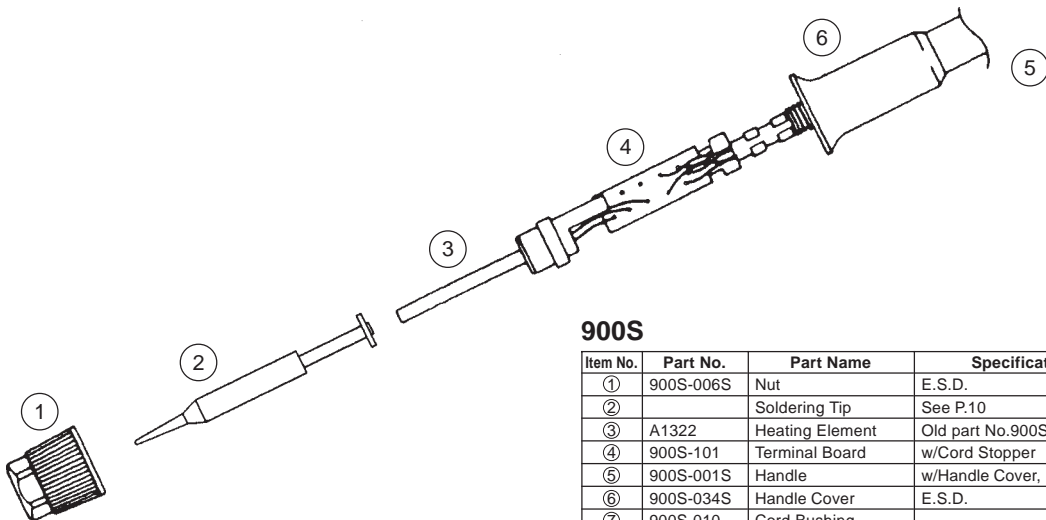

900S

Item No.	Part No.	Part Name	Specifications
①	900S-006S	Nut	E.S.D.
②		Soldering Tip	See P.10
③	A1322	Heating Element	Old part No.900S-H
④	900S-101	Terminal Board	w/Cord Stopper
⑤	900S-001S	Handle	w/Handle Cover, E.S.D.
⑥	900S-034S	Handle Cover	E.S.D.
⑦	900S-010	Cord Bushing	
⑧	900S-039S	Cord Asse'y	E.S.D.

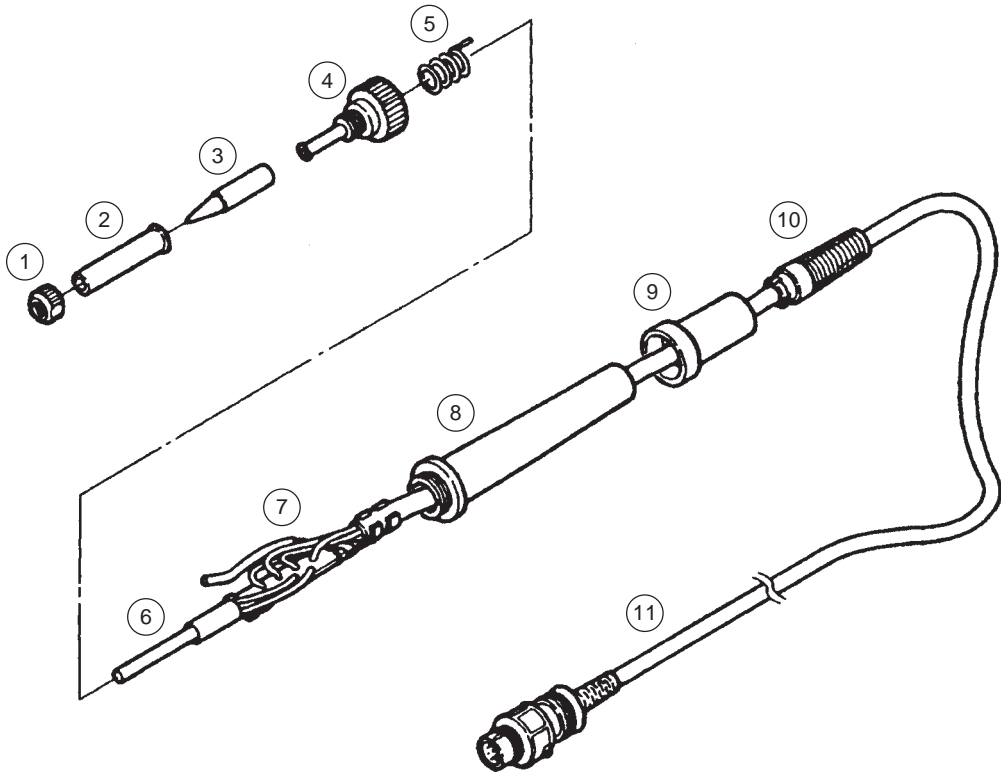

907, 908

Item No.	Part No.	Part Name	Specifications	For
①	B1784	Nut		907
	B1794	Nut		908
②	B1786	Tip Enclosure		907
	B1787	Tip Enclosure		908
③		Soldering Tip	See page 10	907
		Soldering Tip	See page 10	908
④	B2022	Nipple		907
	B2033	Nipple		908
⑤	B2032	Grounding Spring		907, 908

907, 908

Item No.	Part No.	Part Name	Specifications	For
⑥	A1321	Heating Element	Old part No.900M-H 900L-H	907, 908
⑦	B2028	Terminal Board		907, 908
⑧	B2024	Handle	w/Handle Cover, E.S.D	907
	B2026	Handle	w/Handle Cover, E.S.D.	908
⑨	B2027	Handle Cover		907, 908
⑩	B2031	Cord Bushing		907, 908
⑪	B2030	Cord Asse'y	E.S.D.	907, 908

16. WIRING DIAGRAM

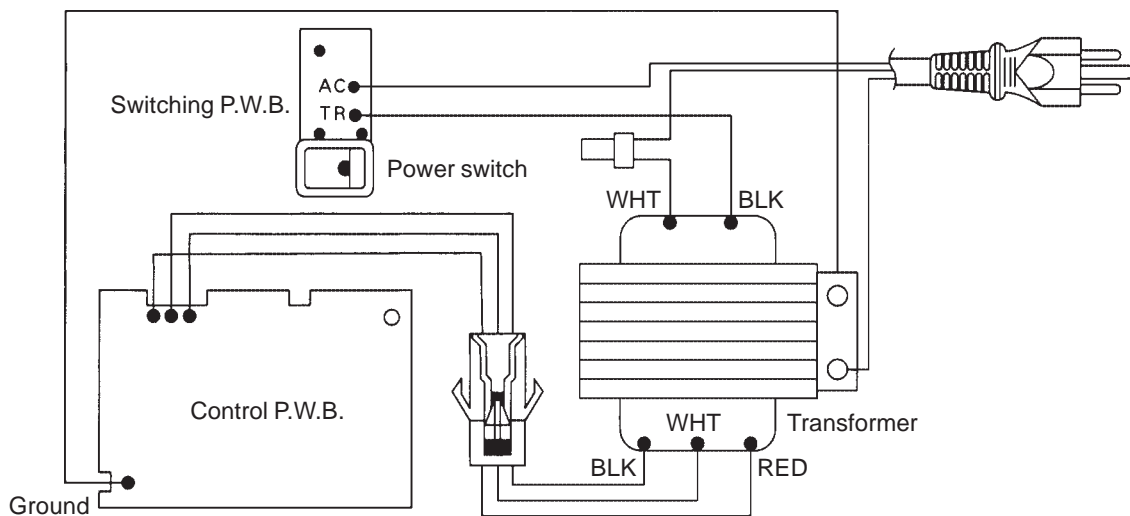



HAKKO CORPORATION

HEAD OFFICE

TEL: +81-6-6561-3225 FAX: +81-6-6561-8466
<http://www.hakko.com> E-mail: sales@hakko.com

OVERSEAS AFFILIATES

U.S.A.: AMERICAN HAKKO PRODUCTS, INC.
TEL: (661) 294-0090 FAX: (661) 294-0096
Toll Free (800)88-HAKKO

<http://www.hakkousa.com>

HONG KONG: HAKKO DEVELOPMENT CO., LTD.

TEL: 2811-5588 FAX: 2590-0217

<http://www.hakko.com.hk>

E-mail: info@hakko.com.hk

SINGAPORE: HAKKO PRODUCTS PTE., LTD.

TEL: 6748-2277 FAX: 6744-0033

<http://www.hakko.com.sg>

E-mail: sales@hakko.com.sg

Please access to the following address for the other Sales affiliates.

<http://www.hakko.com/address>